

Dimensions utiles (mm) :

longueur du décaissement AR	1310
largeur maxi décaissement AR	755
largeur maxi entre sièges AR	440
hauteur int. utile (décaissement)	1440
hauteur de passage (portes AR)	1430
longueur de la rampe d'accès	1040
largeur utile de la rampe d'accès	715
Pente de la rampe	23%

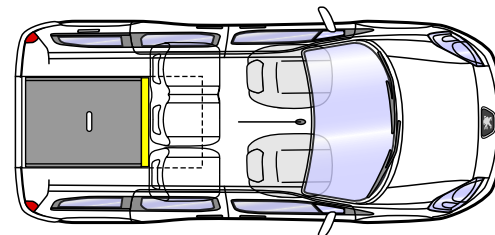

5 + volume coffre d'origine

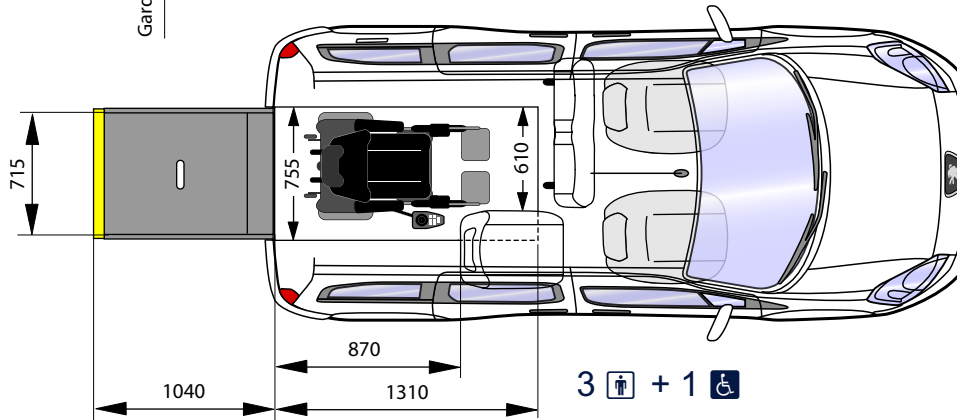
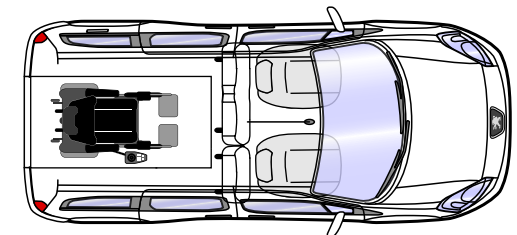

2 + 1